

# immerSiv pro

## XR Panel



### Brief Specs

Pixel Pitch (mm)	2.3	2.6	2.9	3.4
LED Configuration	mini 4 in 1	SMD1515	SMD2020	SMD2020
Pixel Density (pixels/m <sup>2</sup> )	186, 624	147, 456	112, 896	82, 944
Brightness (cd/m <sup>2</sup> )	≥1200	≥1200	≥1200	≥1200
Module Size (W x H mm)	250x500	250x500	250x500	250x500
Panel Size (W x H mm)	500x1000	500x1000	500x1000	500x1000
Panel Resolution (pixels)	216x216	192x384	168x336	144x288
Panel Weight (kg/pc)	12kg	12kg	12kg	12kg
Cabinet Material	Diecast Magnesium	Diecast Magnesium	Diecast Magnesium	Diecast Magnesium
Curveable Angle	-6°, -3°, 0°, +3°, +6°	-6°, -3°, 0°, +3°, +6°	-6°, -3°, 0°, +3°, +6°	-6°, -3°, 0°, +3°, +6°
Power Consumption (w/m <sup>2</sup> )	420 /140	420 /140	420 /140	420 /140
Ingress Progress	IP30	IP30	IP30	IP30
Refresh Rate	7680Hz	7680Hz	7680Hz	7680Hz
Gray Scale	≤16 bits	≤16 bits	≤16 bits	≤16 bits
Frame Frequency	236Hz	236Hz	236Hz	236Hz
Scan Ratio	1/18	1/16	1/14	1/12

### Dimensions

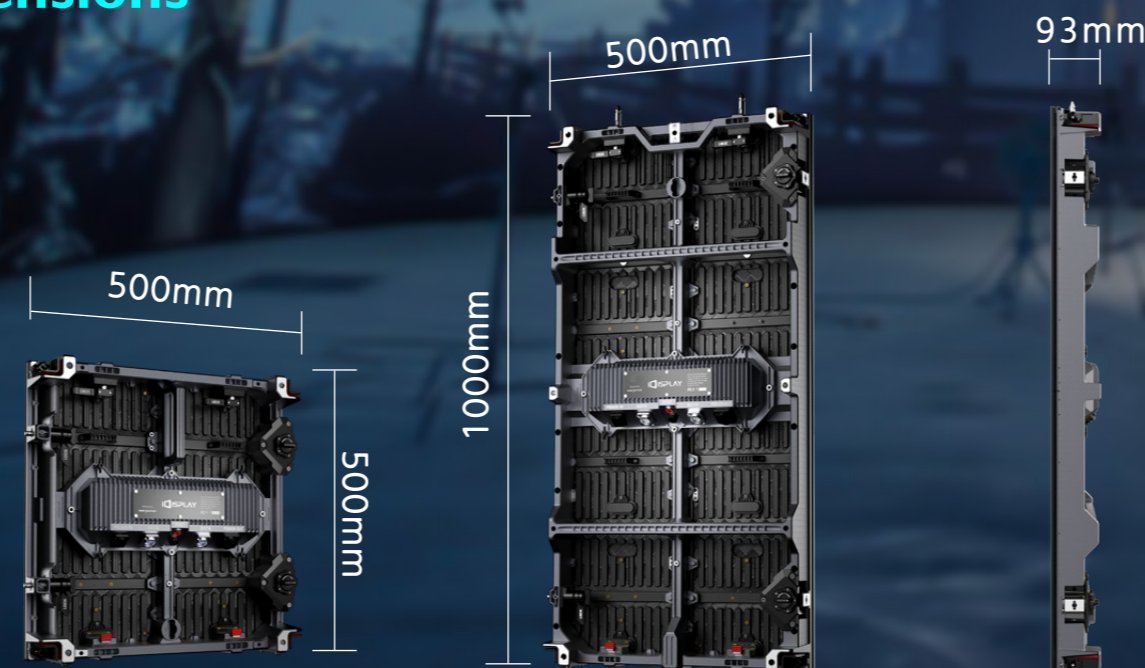

### Super Visuals

The immerSiv pro is able to perform a max refresh rate of 7680Hz, a max frame frequency of 236Hz and a max grayscale of 16 bits.

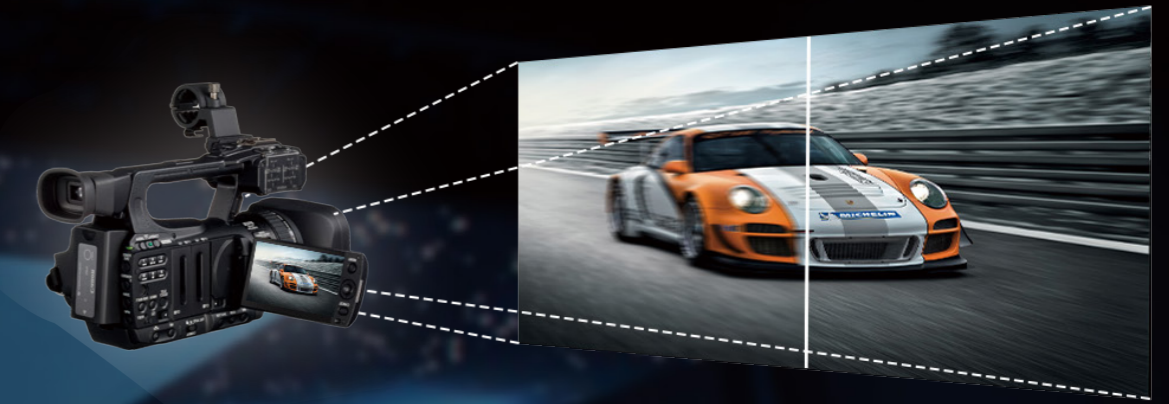

12bits



16bits



1920Hz



7680Hz

**iDISPLAY**

**Shenzhen iDisplay Technology Co.,Ltd.**

Add: 3rd Floor,5th Building, FLT industrial park, Longhua, Shenzhen, China  
 Factory: 5th Building, No.6 of Xinhua Avenue, Chengjiang, Zhongkai, Huizhou, China  
 Tel phone: 86-755-85280348  
 E-mail: hello@idisplayled.com

immerSiv pro has been specifically developed for use in Film & TV industries as well as extended reality applications. The XR panel offers trusted reliable performance with sophisticated & high-speed components such as wide color gamut LEDs, high speed & high grayscale IC drivers and broadcast standard processing.

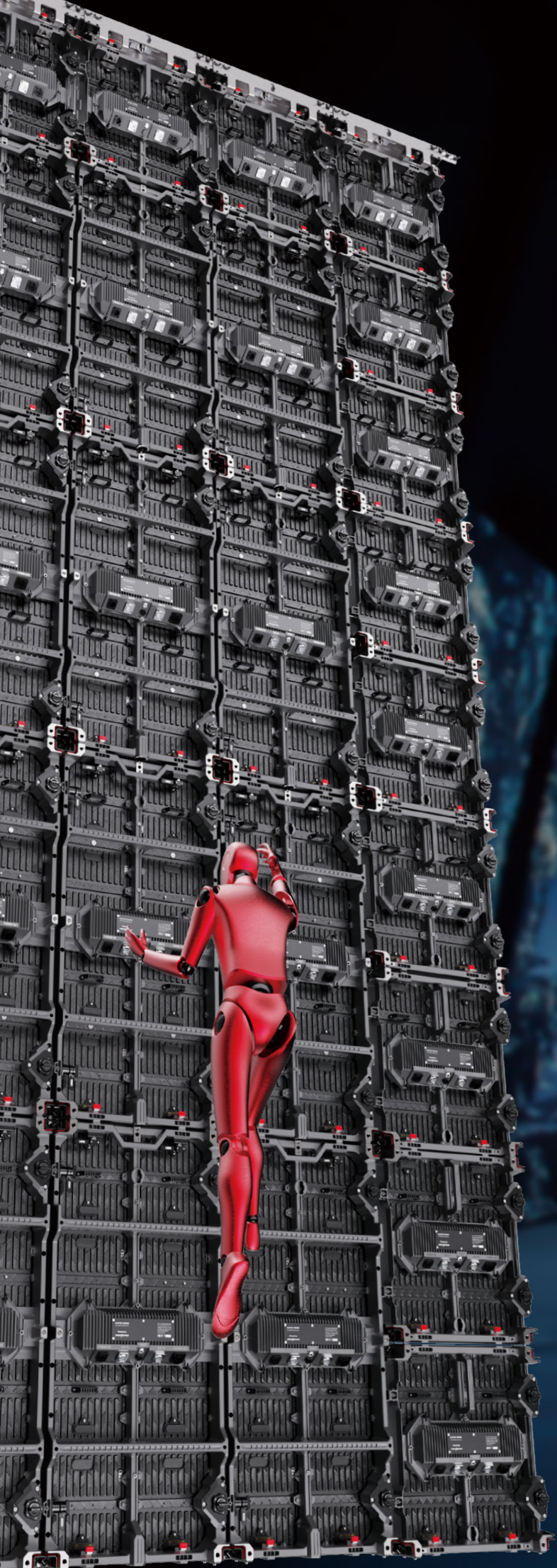

### Smart Fly & Stack Bar

Sideways adjustable rigging clamp assists with truss webbing

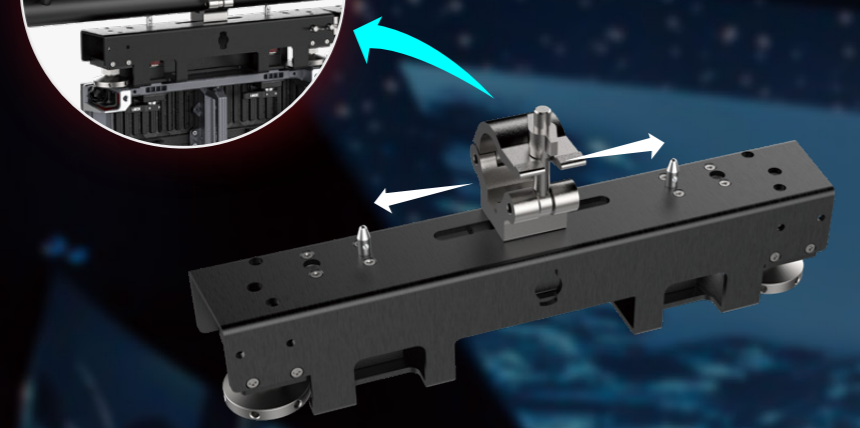

### A Solution of Lightweight & Fast Installing

immerSiv pro accommodates fast construction with its big & lightweight panels, smart latch & itself assisted system, besides, one person is able to complete a full assembling work.



Ver latch push & tighten



Hor latch push, 1/4 turn & tighten



12kg

### Creative Applications

immerSiv pro allows you to realize many creative solutions. In addition to standard designs, immerSiv pro panels can be curved, ceiling mounted, or right angles. That is why immerSiv pro is so popular for xR and virtual production studio.

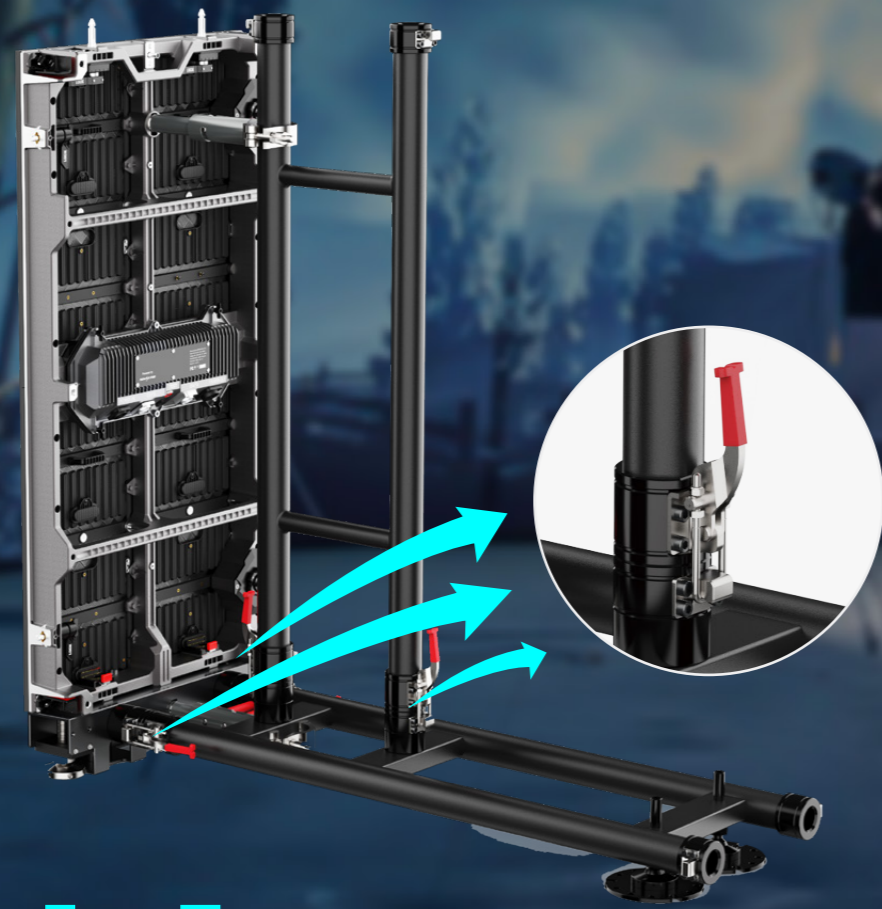
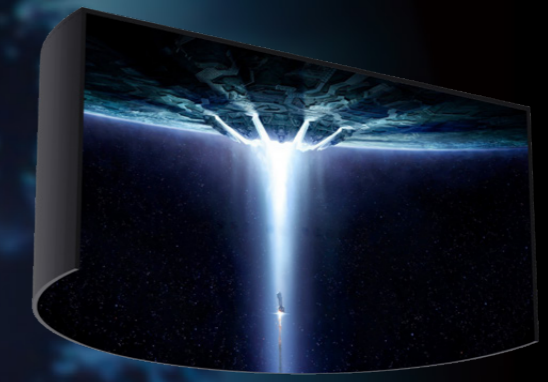
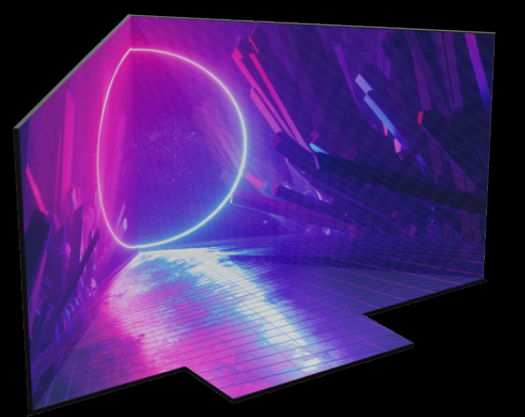

Ease Truss available for ground stack

### Modular & Universal Parts

All parts front and rear serviceable.

